



## AEROPAC Spring 2017 Newsletter



Photo courtesy of Tony Alcocer

### President's Pad

Greetings, fellow AEROPAC members.

Tony Alcocer has been busy this winter building some new launch pads that have the small (1010) and large (1515) rails on the same pad. We will be trying those out this year. Thanks Tony!

Our launch site is underwater, so sadly I must cancel MUDROCK. Even the old timers have never seen this much water on the playa. Hopefully it will dry enough for the Aeronaut launch. I am so sorry.

Reno is doing some training exercises during the ARLISS/XPRS timeframe and they want to use the MOA. That means that we can't use the larger BR15 cylinder of airspace. That will restrict our altitude to 60,000 with recovery within 3.5 miles.

### What's Inside

**Page 2 - Pink O Project, John Ballard**

**Page 6 - AEROPAC Cleaning Party, Peter Hackett**

**Page 7 - 2017 S4: Technology and Program Overview, Ken Biba and Paul Hopkins**

**Page 18 - 2017 S4: Opportunity for TARC Finalists, Ken Biba**

**Page 19 - 2017 S4: Students Earth Science with Smart Eggs, Ken Biba**

**Page 21 - 54MM-MD-1, Juniper Slouber**

**Page 25 - More Awards for Dr. Cominsky**



## Pink O Project—Summer 2017

John Ballard

The Pink O project is a scratch built rocket project slated for maiden launch in the summer of 2017. The project consists of a design similar to my preceding rocket project called “Scrap Yard Cinderella” (SYC). SYC previously shredded at max Q on a scratch built N2400 motor.

Pink O is built more robustly than SYC in the fin can and nose cone. Additionally the motor that is slated for maiden flight is a slightly kinder and gentler scratch built motor that static tests out at N1900. A few of the air frame components and all of the motor components that survived the shred are reused in Pink O.

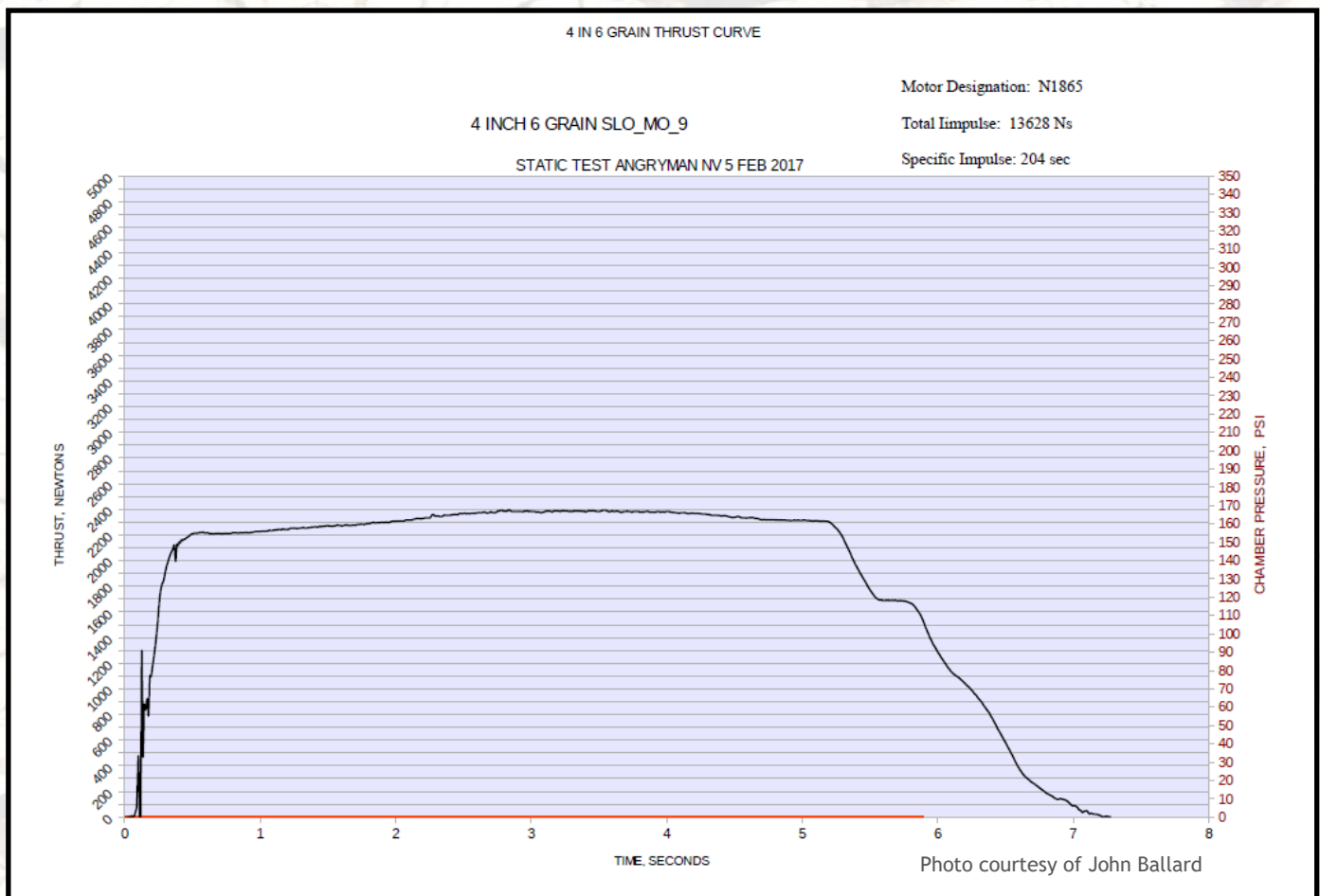

## Pink O Project—Summer 2017

John Ballard



Photo courtesy of John Ballard

The fortified fin can is aluminum.

The electronics bay is salvaged from SYC and rebuilt with dual Missile Works RRC3 flight controllers.

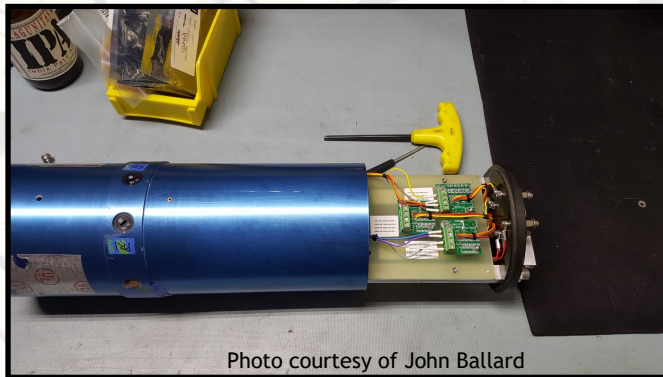

Photo courtesy of John Ballard

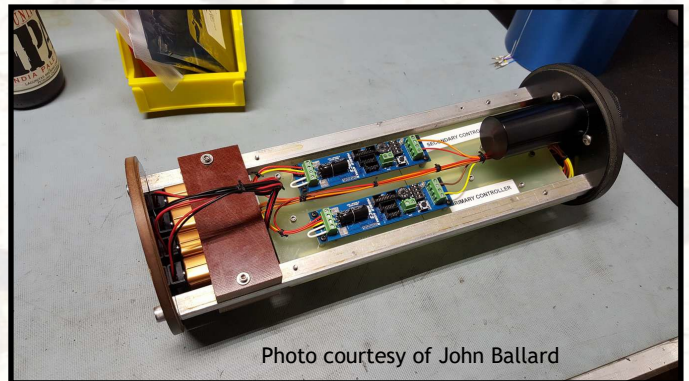

Photo courtesy of John Ballard

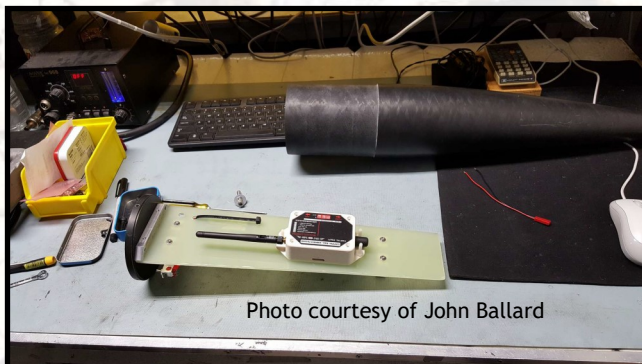

Photo courtesy of John Ballard

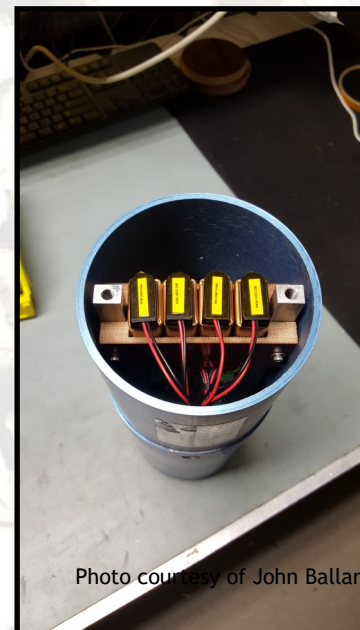

Photo courtesy of John Ballard



## Pink O Project—Summer 2017

John Ballard

The payload bay will initially hold a Raven flight controller to capture dynamic flight data.

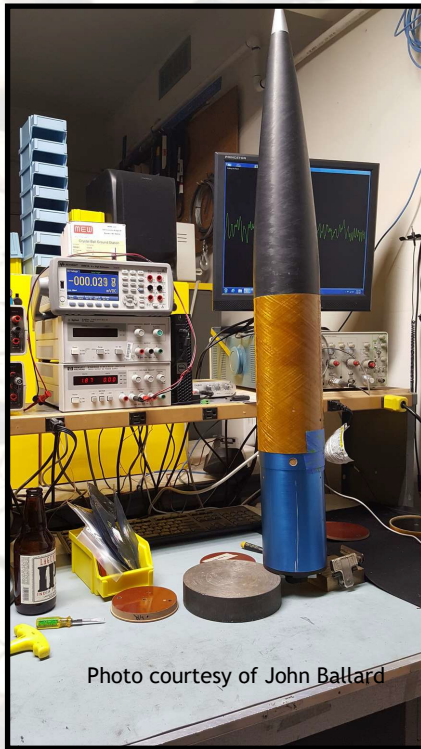

Photo courtesy of John Ballard

Open Rocket software was used and simulations indicate approximate 24,000 ft apogee.

The project is single deployment using a Rouse Tech CO2 ejection and small Fruity Chutes parachute.



Photo courtesy of John Ballard

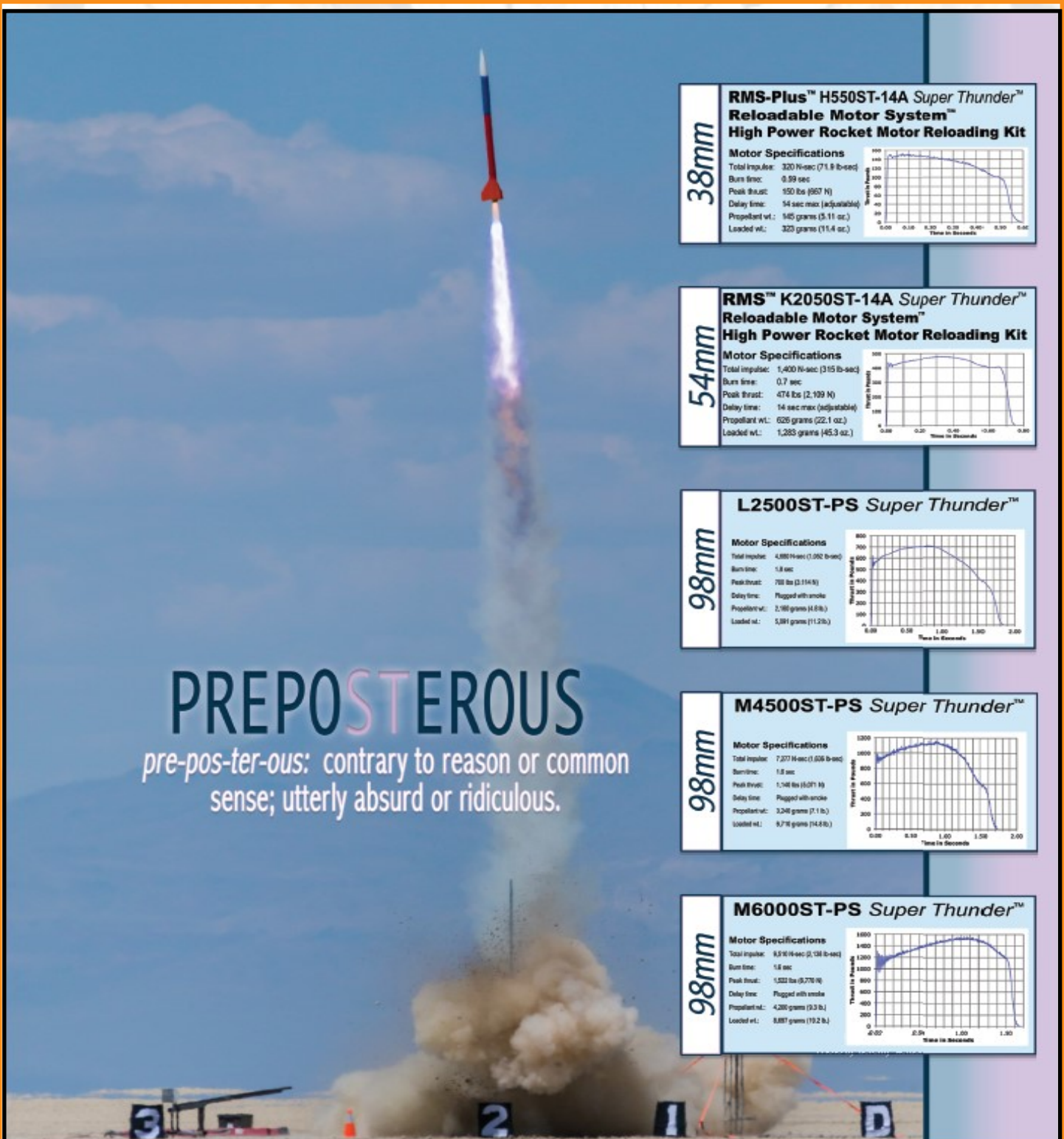

# PREPOSTEROUS

*pre-pos-ter-ous: contrary to reason or common sense; utterly absurd or ridiculous.*

**38mm**

**RMS-Plus™ H550ST-14A Super Thunder™ Reloadable Motor System™ High Power Rocket Motor Reloading Kit**

**Motor Specifications**

- Total impulse: 320 N-sec (71.9 lb-sec)
- Burn time: 0.59 sec
- Peak thrust: 150 lbf (667 N)
- Delay time: 14 sec max (adjustable)
- Propellant wt.: 545 grams (5.11 oz.)
- Loaded wt.: 323 grams (11.4 oz.)

**54mm**

**RMS™ K2050ST-14A Super Thunder™ Reloadable Motor System™ High Power Rocket Motor Reloading Kit**

**Motor Specifications**

- Total impulse: 1,400 N-sec (315 lb-sec)
- Burn time: 0.7 sec
- Peak thrust: 474 lbf (2,109 N)
- Delay time: 14 sec max (adjustable)
- Propellant wt.: 626 grams (22.1 oz.)
- Loaded wt.: 1,283 grams (45.3 oz.)

**98mm**

**L2500ST-PS Super Thunder™**

**Motor Specifications**

- Total impulse: 4,880 N-sec (1,092 lb-sec)
- Burn time: 1.8 sec
- Peak thrust: 700 lbf (3,114 N)
- Delay time: Plugged with anode
- Propellant wt.: 2,766 grams (9.8 lb)
- Loaded wt.: 5,881 grams (12.9 lb)

**98mm**

**M4500ST-PS Super Thunder™**

**Motor Specifications**

- Total impulse: 7,277 N-sec (1,628 lb-sec)
- Burn time: 1.8 sec
- Peak thrust: 1,146 lbf (5,071 N)
- Delay time: Plugged with anode
- Propellant wt.: 3,246 grams (11.4 lb)
- Loaded wt.: 8,716 grams (19.0 lb)

**98mm**

**M6000ST-PS Super Thunder™**

**Motor Specifications**

- Total impulse: 8,516 N-sec (1,910 lb-sec)
- Burn time: 1.8 sec
- Peak thrust: 1,532 lbf (6,776 N)
- Delay time: Plugged with anode
- Propellant wt.: 4,266 grams (15.3 lb)
- Loaded wt.: 8,887 grams (19.6 lb)



## Technical by Design.

[www.aerotech-rocketry.com](http://www.aerotech-rocketry.com)

©2016 PCS Rocket Motor Components, Inc. 2113 W 850 N, Cedar City, UT 84721 [www.aerotech-rocketry.com](http://www.aerotech-rocketry.com)





## 2017 AEROPAC Cleaning Party

## Photos by Peter Hackett





## 2017 S4: Small Satellites for Secondary Students

### Technology and Program Overview

**Ken Biba, Paul Hopkins**

The S4 (Small Satellites for Secondary Students) student satellite system is an opportunity to do payload science targeted to advanced middle and high school students - but also useful to a much wider range of curious experimenters. It is based on the over 17 year ARLISS program of university 1 student payloads that produced CanSats and autonomous recovery robots.

The S4 vision is to imagine a progression of science missions rooted in missions on the ground or on small rockets such as TARC2, progressing to missions to a few thousand meters on High Power hobby rockets (like ARLISS), extending to PocketQube sounding rocket or high altitude balloon missions to 10s of kilometers high (like ARLISS Extreme) and eventually to PocketQube missions deployed into Low Earth Orbit. Each step will stretch student abilities with incremental increases in scope, risk and cost.

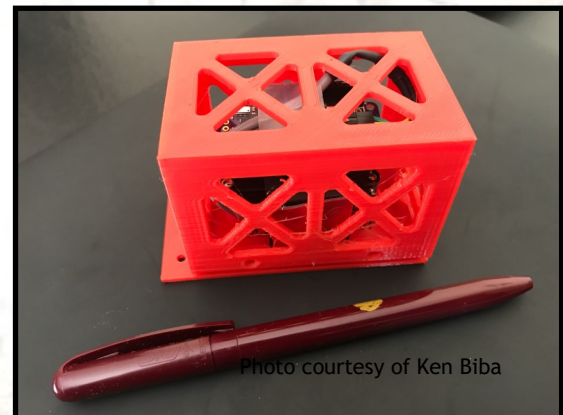

The wide range of sensors and extensibility of the S4 system allow for missions in the atmosphere or on the ground that are largely only limited by the user's imagination.

- Atmosphere science measuring dust, organic compounds, temperature, pressure, humidity, gases
- Measurement of ground and vegetation using visible and IR imaging
- Vehicle dynamics measuring drag, vehicle orientation, position, trajectory using GPS, accelerometers, gyros, magnetometers
- Airframe control for recovery through servos and/or pyrotechnics
- Satellite recovery after apogee deployment<sup>3</sup> via parachute or mechanically actuated recovery like steered parasails
- Gamma ray radiation measurements.

Each S4 satellite payload is inspired by the new standard 1.5p PocketQube<sup>4</sup> picosatellite format



(5 x 5 x 7.5 cm, ~300 gm) - invented by Professor Bob Twiggs, inventor of CanSats and co-inventor of CubeSats. Each S4 satellite contains an array of sensors and is programmed as an advanced Internet of Things computer. Configurations with minimal sensors can be as inexpensive as \$50, and full-up configurations with multiple sensors and telemetry can reach over \$200. Core data collection loops can exceed 100 Hz, with full sensor complement loops can deliver 30 Hz of multi sensor data collection performance.

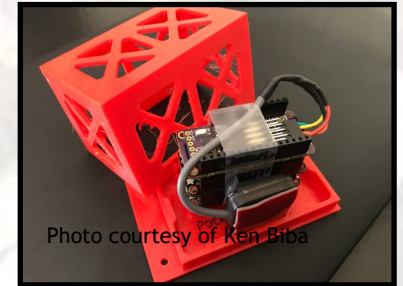

Photo courtesy of Ken Biba

For all but the most basic platforms, S4 uses modern spread spectrum long range radio communications to communicate to ground stations and download telemetry from the mission.

The system is extensible and new sensors can be added to each S4 satellite for new and different missions.

Users can make use of the default sensors and mission programming or add new sensors or programming.

S4 satellites are designed to be flown on rockets as small as TARC rockets or drones that fly a standard hen's egg size payload on F and G motors to 1000' up to High Power sounding rockets or balloons that reach the top of the stratosphere. S4 satellites can be configured for either captive flights or to be deployed at apogee on a recovery device for independent descent. The PocketQube format allows for an incremental transition to an ultimate space capable packaging suitable for LEO deployment.

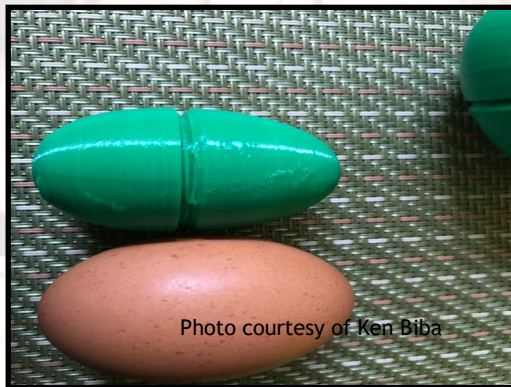

Photo courtesy of Ken Biba

The S4 program anticipates rapid technology changes in platforms and sensors and has tried to standardize on common standards for programming language, packaging, communications and sensor interfaces.

## Mission Software

S4 is based a common satellite mission software package that includes:

- Management drivers for each sensor to initialize and collect data from each sensor;
- Communications protocols for telemetry of sensor data to the ground and for receipt and for receipt of





commands to the satellite;

- Data collection that
- polls configured sensors,
- periodically saves sensor data to local storage - generally a microSD flash memory card,
- wirelessly transmits sensor data to the ground station,
- listens for commands from the ground station to the satellite.
- Ground station software to receive telemetry from mission satellites and transmit commands from the ground.

For S4Egg and S4 Arduino this package is written in C/C++ and is hosted on the Arduino IDE. A version in Python is in development for the S4Pi.

## Platforms

2017 S4 provides three standard platforms to accommodate different missions. All platforms are powered by a 3.7V LiPo battery sized for the mission and configuration. Small configurations, such as S4 Egg, are powered by as little as 100 mAh, while more robust configurations require 500 mA, each delivering hours of operation.

There are three S4 baseline configurations.

Platform	Package	Processor	Data Storage	Communications	Sensor Capacity	Scope
S4Egg	3D printed plastic package in hen's egg size, to match TARC payload	Arduino Zero C/C++	microSD	None	< 4	Entry level S4 satellite designed to be flown in TARC compatible rockets as a subset of PocketQube
S4 Arduino	1.5p PocketQube, 3D printed plastic	Arduino Zero C/C++	microSD	LoRa telemetry WiFi (optional)	< 10	Standard Arduino platform with local storage, telemetry and substantial sensor capacity.
S4Pi	1.5p PocketQube	Raspberry Pi Zero W Python	microSD	LoRa + WiFi - 802.11n telemetry	< 10	Standard PQ with RaspPi Pi platform. Additional computing capability, high performance telemetry,



S4Egg is based on Adafruit Feather M0 platform. It provides an Arduino compatible 64 MHz ARM processor with substantial processing, memory, and I/O resources. The S4Egg has a standard baseline sensor suite designed for crowd-sourced earth science of atmospheric temperature, humidity, pressure, CO2 concentration and Total Volatile Organic Compound (TVOC) measurement. It has a limited capability for sensor expansion using standard S4 sensor interfaces. It has no baseline telemetry capability and stores mission data locally on microSD. The platform includes a serial port, a digital/analog port and an I2C port for sensor expansion.

S4Egg is programmed in the C/C++ Arduino environment using the Arduino IDE development environment. The standard S4 mission program can be used to collect data and as a baseline for adding new sensors and experiments.

Processor, memory, I/O, microSD storage	<a href="https://www.adafruit.com/product/2796">https://www.adafruit.com/product/2796</a>	\$19.95
S4 sensor board	To be published	~\$3.00
3x4 sensor interface header	<a href="https://www.adafruit.com/product/816">https://www.adafruit.com/product/816</a>	\$0.74
Humidity, temperature, atmospheric pressure, equivalent CO2, Total Volatile Organic Compounds sensor	<a href="https://www.tindie.com/products/onehorse/air-quality-sensors/">https://www.tindie.com/products/onehorse/air-quality-sensors/</a>	\$35.95
Feather low profile female header	<a href="https://www.adafruit.com/product/2940">https://www.adafruit.com/product/2940</a>	\$1.50
Feather short male header	<a href="https://www.adafruit.com/product/3002">https://www.adafruit.com/product/3002</a>	\$0.50
150 mAh LiPo battery	<a href="https://www.adafruit.com/product/2750">https://www.adafruit.com/product/2750</a>	\$6.95
3D printed plastic egg enclosure	To be published	~\$3.00

The S4Arduino is based on the same basic hardware platform as the S4Egg - the Adafruit Feather M0. It adds the baseline S4Arduino sensors include: flight capable GPS, 3x accelerometer, 3x gyro, 3x magnetometer, external temperature, atmospheric pressure, battery status. Possible optional sensors include CO2 concentration, humidity, UV+IR+visible light intensity, simple IR imaging, gamma ray radiation, dust and external video. A microSD card provides for local recording of sensor data and a LoRa wireless data-connection provides for real-time data telemetry. The platform includes a serial port, a digital/analog port and an I2C port for sensor expansion.



It is programmed with the Arduino IDE and the standard S4 mission software.

Processor, memory, I/O, microSD storage	<a href="https://www.adafruit.com/product/2796">https://www.adafruit.com/product/2796</a>	\$19.95
LoRa telemetry radio, Feather	<a href="https://www.adafruit.com/product/3231">https://www.adafruit.com/product/3231</a>	\$19.95
S4 sensor board	To be published	~\$3
Atmospheric pressure (to over 100k' MSL), temperature, 9DOF orientation	<a href="https://www.tindie.com/products/onehorse/lsm9ds1ms5611-breakout-board/">https://www.tindie.com/products/onehorse/lsm9ds1ms5611-breakout-board/</a>	\$29.95
3x4 sensor interface header	<a href="https://www.adafruit.com/product/816">https://www.adafruit.com/product/816</a>	\$0.74
uBlox 3D dynamics flight rated GPS		\$20.00
Feather low profile female header	<a href="https://www.adafruit.com/product/2940">https://www.adafruit.com/product/2940</a>	\$1.50
Feather short male header	<a href="https://www.adafruit.com/product/3002">https://www.adafruit.com/product/3002</a>	\$0.50
Feather stacking header	<a href="https://www.adafruit.com/product/2830">https://www.adafruit.com/product/2830</a>	\$1.25
3D printed 1.5p PocketCube enclosure	To be published	~\$3

S4Pi is based on the Raspberry Pi Zero W platform. The platform includes both a LoRa radio, a WiFi radio, a microSD for local storage, flight capable GPS, 3x accelerometer, 3x gyro, 3x magnetometer, temperature, pressure and battery status. A standard RaspPi video camera is included. Possible optional sensors include CO2 concentration, humidity, UV+IR+visible light intensity, simple IR imaging, gamma ray radiation, and dust.

Raspberry Pi Zero W	<a href="https://www.adafruit.com/product/3400">https://www.adafruit.com/product/3400</a>	\$10.00
S4Pi Motherboard	To be published. Processor board + 3 extensions pHats	~\$3
S4Pi Sensor Board	To be published. Extension pHats hosting 9DOF sensor and LoRa telemetry radio	~\$3
S4Pi Camera	<a href="https://www.adafruit.com/product/3099">https://www.adafruit.com/product/3099</a>	\$29.95



S4Pi Camera Cable	<a href="https://www.adafruit.com/product/3157">https://www.adafruit.com/product/3157</a>	\$5.95
900 MHz LoRa Daughterboard	<a href="https://www.adafruit.com/product/3072">https://www.adafruit.com/product/3072</a>	\$19.95
MS5611+LSM9DS1	<a href="https://www.tindie.com/products/onehorse/lsm9ds1ms5611-breakout-board/">https://www.tindie.com/products/onehorse/lsm9ds1ms5611-breakout-board/</a>	\$29.95
1.5P package	To be published.	~\$3

The platform includes a serial port, a digital/analog port and an I2C port for sensor expansion.

### Packages

S4 has two packages for the three platforms. The S4Egg package is a 3D printed plastic enclosure, in the volume of a chicken egg - 45mm in diameter. It has sufficient capacity for the core Arduino processor, battery, the baseline S4Egg sensors and extension connectors for I2C, serial, and digital/analog ports.



Photo Courtesy of Ken Biba

S4Arduino and S4Pi share the 1.5p PocketQube package. It is a 3D printed 5x5x7.5 cm plastic enclosure designed to hold the core processor, baseline sensors, battery, antennas, and additional sensors. About half the volume of the S4Arduino is available for optional sensors. The S4 electronics are expected to be space capable for short missions to LEO. It is anticipated that the plastic PocketQube form factor will be upgraded to a 3D printed space cable material and format.

### Standard Sensor Interface

S4 defines three external sensor interfaces, each defined as a simple four wire interface using a standard .1" 4 pin connector. All platforms use the same interfaces. Standard Arduino C/C++ sensor libraries are shared between S4Egg and S4Arduino in the S4 Mission Software. A separate library is necessary for the Python version of SMS for the S4Pi.

Type	Pins
Serial	3.3v, Tx, Rx, GND
I2C	3.3v, SDA, SCL, GND
Digital/Analog (D/A)	3.3v, Digital I/O, Analog I/O/PWM, GND



All of the S4 platforms also support an SPI interface, generally limited to communications and internal storage peripherals and not generally supported as an external sensor interface.

S4Pi also supports USB.

### Sensors

The S4 system uses an open-ended collection of sensors to measure position, light, atmosphere, radiation and multispectral imaging. The same sensor interfaces are used by all platforms.

The following table represents sensors that can fit in the package, have supported drivers for at least one S4 platform, and are believed to collect useful data during rocket flight.

The list is under continual review as flight experience is accumulated and as new sensors are available and missions are imagined.

Measurement	Sensor	Description/Link	S4Eg	S4Ar	S4Pi
			g	duino	o
			S	O	S
Time	uBlox 7 GPS Cortex M0 clock	.5 sec with 2 Hz refresh rate.	✓	✓	✓
Location	uBlox 7 GPS	3m RMS horizontal precision.	✓	✓	✓
Geometric Altitude	uBlox 7 GPS	10m RMS vertical precision.	✓	✓	✓
Ambient atmospheric pressure	Measurement Specialties MS5611	Rated to 0 Pa pressure. Over 100k' MSL altitude <a href="https://www.tindie.com/products/onehorse/lsm9ds1ms5611-breakout-board/">https://www.tindie.com/products/onehorse/lsm9ds1ms5611-breakout-board/</a>		✓	✓
	Bosch BME280	30,000Pa to 110,000Pa ~30k' MSL altitude <a href="https://www.tindie.com/products/onehorse/air-quality-sensors/">https://www.tindie.com/products/onehorse/air-quality-sensors/</a>	✓	✓	✓
Ambient atmospheric temperature	Measurement Specialties MS5611	<a href="https://www.tindie.com/products/onehorse/lsm9ds1ms5611-breakout-board/">https://www.tindie.com/products/onehorse/lsm9ds1ms5611-breakout-board/</a>		✓	✓
	Bosch BME280	-40C to 85C <a href="https://www.tindie.com/products/onehorse/air-quality-sensors/">https://www.tindie.com/products/onehorse/air-quality-sensors/</a>	✓	✓	✓
	Microchip MCP9808	High precision external temperature <a href="https://www.adafruit.com/product/1792">https://www.adafruit.com/product/1792</a>	✓		✓
Acceleration	ST LSM9DS1	3D acceleration sensor. Up to 16gs. Software absolute position: roll, pitch, yaw. <a href="https://www.tindie.com/products/onehorse/lsm9ds1ms5611-breakout-board/">https://www.tindie.com/products/onehorse/lsm9ds1ms5611-breakout-board/</a>	✓	✓	✓
	Bosch BNC055	3D acceleration sensor. Up to 16gs. Hardware absolute position: roll, pitch, yaw. <a href="https://www.adafruit.com/product/2472">https://www.adafruit.com/product/2472</a>	✓	✓	



Magnetic field	ST LSM9DS1	3D magnetic field sensor. Software absolute position: roll, pitch, yaw. <a href="https://www.tindie.com/products/onehorse/lsm9ds1ms5611-breakout-board/">https://www.tindie.com/products/onehorse/lsm9ds1ms5611-breakout-board/</a>	√	√	√
	Bosch BNO055	3D magnetic field sensor. Hardware absolute position: roll, pitch, yaw. <a href="https://www.adafruit.com/product/2472">https://www.adafruit.com/product/2472</a>	√	√	
Rotation	ST LSM9DS1	3D gyro, rotation sensor. Software absolute position: roll, pitch, yaw. <a href="https://www.tindie.com/products/onehorse/lsm9ds1ms5611-breakout-board/">https://www.tindie.com/products/onehorse/lsm9ds1ms5611-breakout-board/</a>	√	√	√
	Bosch BNO055	3D gyro, rotation sensor. Hardware absolute position: roll, pitch, yaw. <a href="https://www.adafruit.com/product/2472">https://www.adafruit.com/product/2472</a>	√	√	
Ambient IR light	AMS-TAOS TSL2591	<a href="https://www.adafruit.com/product/1990">https://www.adafruit.com/product/1990</a>	√	√	√
Ambient Visible light	AMS-TAOS TSL2591	<a href="https://www.adafruit.com/product/1990">https://www.adafruit.com/product/1990</a>	√	√	√
Ambient UV light	Vishay VEML6070	<a href="https://www.adafruit.com/product/2899">https://www.adafruit.com/product/2899</a>	√	√	√
Spot IR temperature sensor	Melexis MLX90614	10 degree FoV spot IR sensor. Determine average ground temperature. Vegetation. <a href="https://www.sparkfun.com/products/9570">https://www.sparkfun.com/products/9570</a>	√	√	√
IR imaging sensor	Panasonic AMG8833	8x8 array of IR sensors for primitive IR imaging. 60 degree total FOV <a href="https://www.tindie.com/products/onehorse/grid-eye-8-x-8-ir-array/">https://www.tindie.com/products/onehorse/grid-eye-8-x-8-ir-array/</a>		√	√
CO <sub>2</sub>	AMS CSS811	CO <sub>2</sub> detector - 400-8192 ppm <a href="https://www.tindie.com/products/onehorse/air-quality-sensors/">https://www.tindie.com/products/onehorse/air-quality-sensors/</a>	√	√	√
TVOC	AMS CSS811	Volatile organic compounds - 0-1187 ppb. Ethane, propane, formaldehyde, others <a href="https://www.tindie.com/products/onehorse/air-quality-sensors/">https://www.tindie.com/products/onehorse/air-quality-sensors/</a>	√	√	√
Humidity	Bosch BME280	0 - 100% RH, ±3% from 20-80% <a href="https://www.tindie.com/products/onehorse/air-quality-sensors/">https://www.tindie.com/products/onehorse/air-quality-sensors/</a>	√	√	√
Dust	Sharp GP2Y1010AU0F	Optical dust sensor <a href="http://www.waveshare.com/dust-sensor.htm">http://www.waveshare.com/dust-sensor.htm</a>		√	√
Gamma Radiation	First X100-7	PIN silicon photodiode radiation detector. Detects 0.002-1.0 MeV gamma rays. <a href="https://www.sparkfun.com/products/14209">https://www.sparkfun.com/products/14209</a>		√	√
Local video		S4 local stored video <a href="https://www.adafruit.com/product/3202">https://www.adafruit.com/product/3202</a>		√	√
Streaming video		Video, both stored locally and streamed to ground in real-time <a href="https://www.adafruit.com/product/3414">https://www.adafruit.com/product/3414</a>		√	



## Communications and Telemetry

The S4 system defines two wireless communications methods, one for long range, low power telemetry and the other for shorter range, high performance communications.

Platform	Telemetry Choices
S4Egg	None LoRa 868/902-928 MHz (optional)
S4 Arduino	LoRa 868/902-928 MHz WiFi (2.4 GHz, 802.11n, 20 dBm (optional))
S4Pi	LoRa 902-928 MHz/868 MHz WiFi (2.4 GHz, 802.11n, 20 dBm)

An emerging wireless standard for the Internet of things, LoRa, is used as the basis for long range, low power S4 telemetry service in the 868 MHz unlicensed band in Europe and the 902-928 MHz unlicensed band in the Americas. LoRa is based on a variant direct sequence spread spectrum modulation system that provides up to 30 dB of additional radio link budget depending on desired throughput vs range performance. It is packaged for high volume applications with a single chip controller+radio implementation available for less than \$5 with 20 dBm of TX power and over 148 dB of potential effective receiver gain.

The radio link can be software configured to trade off range vs throughput. Tracking ranges exceeding 200 km are anticipated, at 900 MHz using omnidirectional antennas in both payload and ground station. Modest directional ground station antennas can double that range. Telemetry speeds range from 100s of b/s ranging to 10s of kb/s are possible. S4 uses the standard RadioHead<sup>10</sup> Arduino communications library to provide the basic protocol structure. S4 uses software tunable LoRa radios in the 902-928 MHz unlicensed band. S4's telemetry protocol has bidirectional capability - for telemetry from the satellite and commands from the ground. The protocol is Listen-Before-Talk allowing multiple shared satellites on a common telemetry frequency channel. Satellites on the same channel can share ground stations and satellite telemetry can be received by multiple ground stations. Up to 255 satellites and ground stations can be configured on the same frequency channel.

WiFi is used for high speed, multi-megabit communications using UDP/TCP. Early S4 prototypes using WiFi communications demonstrated rocket telemetry performance up to 3km AGL. With a high gain, inexpensive ground station antenna WiFi ranges exceeding 20 km to S4 payloads may be possible. Both S4Arduino and S4Pi can be configured with a WiFi link. The LoRa telemetry is used for positioning telemetry to the ground station and the payload positioning telemetry is used to point the ground station high gain WiFi antenna. S4 currently uses 802.11n WiFi radios in the 2.4 GHz unlicensed band.



## Telemetry Ground Stations

S4 Arduino and S4Pi have telemetry ground stations that attach to laptops via USB to store and collect

telemetry. The basic LoRa ground station is a single board Adafruit Feather M0 with a LoRa radio with an omnidirectional antenna. The ground station connects to a USB port on a local laptop for a .csv telemetry data stream.

An enhanced ground station adds WiFi for sharing telemetry with Internet hosts via local WiFi hotspot communications to Internet gateways<sup>11</sup>. The S4 Mission Software includes the capability of Internet dashboards monitoring selected mission data on common Internet of Things Internet services.

The advanced S4 ground station adds local GPS, 9DOF positioning sensor, and servo control to enable the ground station to take position telemetry from the payload using LoRa and to then determine the tracking vector to the satellite from the ground station. The ground station then uses this tracking vector to control the servos on the antenna tracking mount to point the WiFi antenna at the payload.

The WiFi antenna has a builtin 802.11n dual polarized MIMO access point delivering 12 Ethernet TCP/UDP packets from the payload. This capability allows for high performance telemetry of streaming video and IR imaging.

The Adafruit Feather platform also provides the ability to add displays and other sensors for differential measurement between satellite and ground station.

### How To Participate

S4 is open source<sup>13</sup> and freely available to be used by anyone. We ask that users share missions, new sensors and modifications with the S4 team in order to share that with the entire S4 community.

The National Association of Rocketry is sponsoring two early programs in 2017 to kickstart S4 in student rocket science. NAR is funding S4 satellites for TARC Finalists - but any student team can join and participate.

The **Student Crowdsourced Atmosphere Pollution Study**<sup>14</sup> - SCAP - uses S4Egg, on the ground and in mid-power rockets to collect measure humidity, temperature, pressure, CO2 and Total Volatile Organic Compounds in the atmosphere column. Data taken by each team will be aggregated and shared with all teams collecting data allowing analysis not just of each team's data, but all the SCAP measurements. NAR has sponsored 30 S4Eggs for 2017 TARC Finalists but anyone can join in.

**ARLISS Explore the Earth** - encourages students to design, implement and report a science experiment about rocketry, the Earth or its atmosphere using the S4Arduino on high power rocket<sup>15</sup>. NAR is sponsoring six TARC teams to do science experiments with S4Arduino but anyone can participate.





Teams request participation by a science mission experiment proposal, which they then design and fly with a local HPR flier. They then write up their results as a science experiment and submit back to the S4 project team for evaluation. The top two teams will then be funded for an ARLISS Extreme sounding rocket flight with their satellite to the top of the stratosphere - over 100k' high at Mach 3.

Contact Ken Biba at [kenbiba@icloud.com](mailto:kenbiba@icloud.com).

1 A Rocket Launch for International Student Satellites is an international high school and university competition for autonomous robotic student satellites held for the last 17 years by the AeroPac rocketry club at Black Rock Nevada. [www.arliss.org](http://www.arliss.org)

2 Team America Rocketry Competition ([www.rocketcontest.org](http://www.rocketcontest.org)) lofting raw egg payloads on mid-power rockets using E thru G motors.

3 Standard ARLISS CanSat deployment.

4 PocketQubes are the successor to CubeSats designed by Professor Bob Twiggs, co-inventor of CubeSats and CanSats. CubeSats are now the standard for modern small satellites - educational, commercial and government. PocketQubes are the successor—reducing the key dimension from 10 cm to 5 cm - recognizing the increase in electronics capability at small size. A number are now in orbit with more on the way. <https://en.wikipedia.org/wiki/PocketQube>

5 Like the ARLISS Extreme sounding rocket, that can carry two S4Arduino payloads over 100k' AGL on commercial motors totaling less than 30k Nsec of total impulse.

6 <https://www.adafruit.com/product/3178>, 48 MHz ARM Cortex M0, 256k FLASH, 32k RAM memory. The Adafruit Feather family includes multiple integrated radio of options including LoRa, WiFi and conventional narrow band FSK.

7 The Feather M0 is about five times “bigger and faster” than the classic Arduino

8 <https://www.lora-alliance.org/What-Is-LoRa/Technology>

9 European high altitude balloon experiments at lower transmitter power and at 433 MHz validate this assumption.

10 <http://www.airspayce.com/mikem/arduino/RadioHead/>

11 Such as those supported in most modern smartphones.

12 <https://www.ubnt.com/airmax/rocketdish-antenna/> These dish antennas are dual polarized MIMO 802.11n with 24 dBm antenna gain,

28 dBm Tx power and -96 dB RX sensitivity at 6 Mb/s link rate. Common consumer prices are under \$80.

13 <https://github.com/kenbiba/S4>

14 <https://github.com/kenbiba/S4/blob/master/2017%20S4Egg4.pdf>

15 <https://github.com/kenbiba/S4/blob/master/2017%20S4Arduino5.pdf>



## 2017 S4: Small Satellites for Secondary Students

Ken Biba

### *Congratulations 2017 TARC National Finalists!*

*This is your opportunity to explore the science of the stratosphere*

The S4 (Small Satellites for Secondary Students) student satellite system is an opportunity to do ARLISS<sup>1</sup> program of university student payloads that invented CanSats. Each S4Arduino payload is based on the new standard 1.5p PocketQube<sup>2</sup> picosatellite format (5 x 5 x 7.5 cm). Each S4Arduino PocketQube contains an array of sensors and is programmed as an advanced Arduino compatible computer. Each S4Arduino uses modern spread spectrum long range radio communications to communicate to the ground and download telemetry from the flight. The system is extensible and new sensors can be added to each S4 for new and different missions. Students can make use of the baseline sensors and programming or add new sensors or programming.

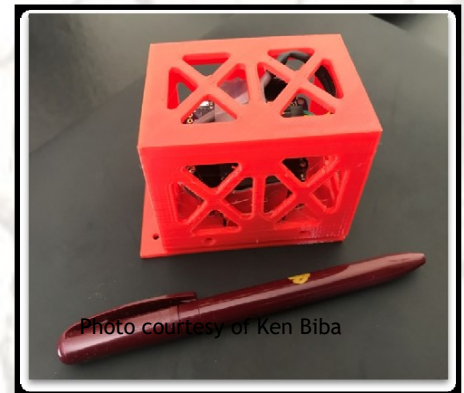

S4 satellites are designed to be flown on 3" (and above) diameter rockets on G motors to 1000' all the way up to sounding rockets reaching the top of the stratosphere. S4 satellites can be configured for either captive flights or to be deployed at apogee on a recovery device for independent descent.

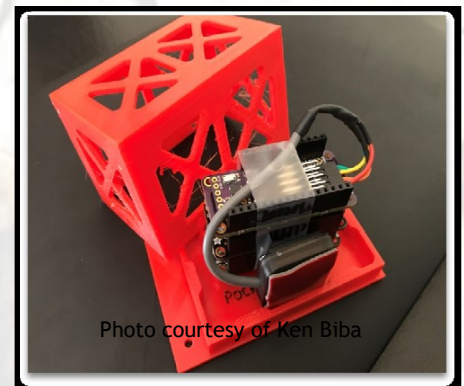

Baseline S4Arduino sensors include: flight capable GPS, 3D accelerometer, 3D gyro, 3D magnetometer, temperature, atmospheric pressure, and battery status. Additional available sensors include light (IR, visible, UV), CO<sub>2</sub> gas, volatile organic compound pollutants, gamma ray radiation, dust concentration, humidity and IR imaging. Standard interfaces are available to add even more sensors. S4Arduino samples data from the baseline sensors at about 50 Hz, stores data locally at about 10 Hz and transmits telemetry at about 1 Hz. The package has enough room for a small video camera. A microSD card provides for local recording of sensor data and a wireless telemetry connection provides for real-time data collection.

<sup>1</sup> A Rocket Launch for International Student Satellites is an international high school and university competition for autonomous robotic student satellites held for the last 17 years by the AeroPac rocketry club at Black Rock Nevada. [www.arliss.org](http://www.arliss.org)

<sup>2</sup> PocketQubes are the successor to CubeSats designed by Professor Bob Twiggs, co-inventor of CubeSats and CanSats. CubeSats are now the standard for small satellites - educational, commercial and government. PocketQubes are the successor - recognizing the increase in electronics capability at small size. A number are now in orbit with more on the way.



## 2017 S4: Small Satellites for Secondary

Ken Biba, AEROPAC, NAR



### Students Earth Science with Smart Eggs

***Congratulations 2017 TARC National Finalists!***

***Let's do some earth science together!***

The S4 (Small Satellites for Secondary Students) student satellite system is an opportunity to do payload science. It is based on the 17+ year ARLISS1 program of university student payloads that invented CanSats. Each **S4Egg** payload is a hen's egg based science payload - a smaller sibling of larger S4 payloads based on the new standard 1.5p PocketQube2 picosatellite format (5 x 5 x 7.5 cm). Each S4Egg contains an array of sensors and is programmed as an advanced Arduino compatible computer. The National Association of Rocketry, in cooperation with the ARLISS program, is sponsoring an experiment in crowd sourced student rocketry earth science using S4Eggs and your TARC rockets. S4Egg satellites are designed to be flown on TARC rockets (or larger!) to do a common earth science experiment collecting data on atmospheric pressure, temperature, humidity, carbon dioxide level, and TVOC (Total Volatile Organic Compound—including formaldehyde) during your flight(s).

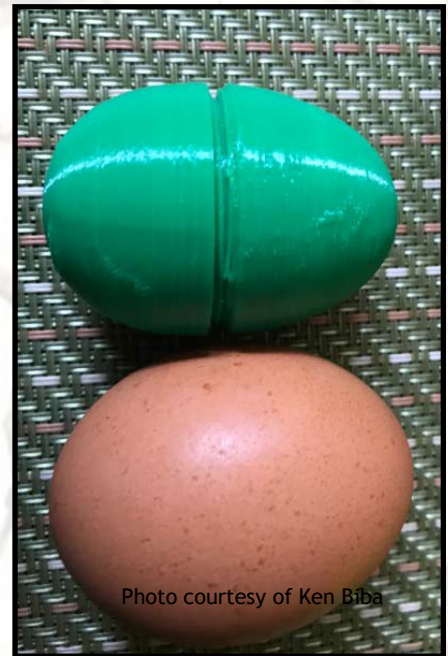

Photo courtesy of Ken Biba

Send the information back to us and we will post that information for all the teams to look at and analyze. Send us your analysis and we will publish that as well. In addition to the common crowd sourced experiment, your S4Egg can be adapted with additional software and sensors to do additional, customized science experiments. Baseline S4Egg sensors include: temperature, atmospheric pressure, humidity, CO2 and TVOC measurements. Additional available S4Egg sensors include GPS, and light (IR, visible, UV) sensors. Standard interfaces are available to add even more sensors. And the S4Egg's electronics can be moved to the larger S4Arduino package for even more sensors (dust, gamma radiation, IR imaging, video) and capability. S4Arduino samples data from the baseline sensors at about 50 Hz, stores data locally at about 10 Hz. A microSD card provides for local recording of sensor data.

### 2017 S4Egg Program

.All 2017 TARC National Finalist teams have the opportunity to participate and it's a simple process.



- 1) Send us ([kenbiba@icloud.com](mailto:kenbiba@icloud.com)) a request to participate (by June 1, 2017).
- 2) 30 participating teams will be selected by the date of their application and geographic location. Selected teams will have their S4Egg shipped to them by mid-summer along with user documentation.
- 3) Fly the S4Egg as many times as you like over the summer and fall, then submit your flight data and analysis by November 1st 2017.
- 4) We will publish all the data and analysis we receive by December 1, 2017 and make the report available to all.
- 5) We then encourage all teams to look at this much larger dataset (hopefully with hundreds of flights across the UnitedStates) - and see if we can find patterns in atmospheric CO2 and volatile organic compounds.

Teams can contact Ken Biba ([kenbiba@icloud.com](mailto:kenbiba@icloud.com)) at AeroPac for more information.

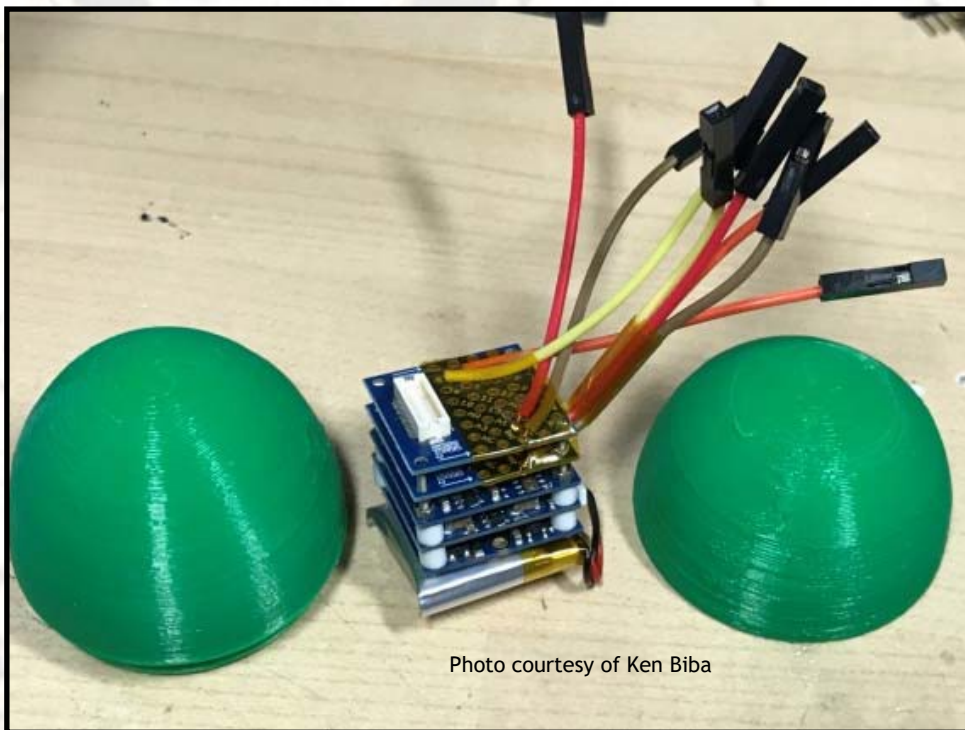

Photo courtesy of Ken Biba





## 54MM-MD-1

The 54mm-MD-1 (54mm minimum diameter) is my first attempt at a high performance rocket. I chose this project after being inspired by Curt Von Delius. He has become a mentor of sorts in my adventures. I first met him at MUDROCK 2016. He and my grandfather (Jonathan DuBose) had already been good friends so we all naturally began sharing our projects and designs. Curt and I discussed some basic ideas about fin designs, etc. and doodled them on the AEROPAC Board meeting agenda. I have tried to incorporate many of these ideas in my design.

Curt's highly compact and innovative designs made me realize the true open-endedness of amateur rocketry. Hoping for a future career in aerospace engineering I thought that high performance and advanced rocketry would be a good place to begin building a foundation for that goal. To begin my career in rocketry I started with getting my TRA Mentoring Program (TMP) certification in May 2016 (See Fall 2016 Newsletter article "High Powered Young Rocketeers").

Curt's "Barney" was my first glimpse of a small minimum diameter design. It is unlike most of his rockets that are "flying motors". I considered using the flying motor technique but I decided that as my first scratch built high powered rocket I should keep it relatively conventional. But in an effort to stay as space efficient as possible I housed all the electronics in the nosecone.

Instead of using traditional dual deploy which takes up a considerably large amount of space I decided to use an apogee separation without a drogue until 1000 feet where the main chute will deploy via the use of a chute release. The custom parachute designed and manufactured by Curt is a cruciform shape. Using spectra for the shroud lines and rip stop nylon for the drag component. I researched integrating an un-reefing system to turn it from a drogue to a main chute at an indicated altitude. It would use a string of some sort looped around the perimeter holding the parachute only partially open. To release it would require a wire cutting charge or something of similar design. This unfortunately proved impossible given the size constraint of the airframe. I will likely attempt this system on a future rocket of a larger size.

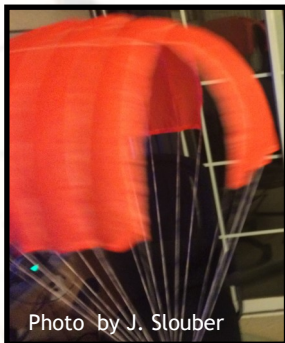
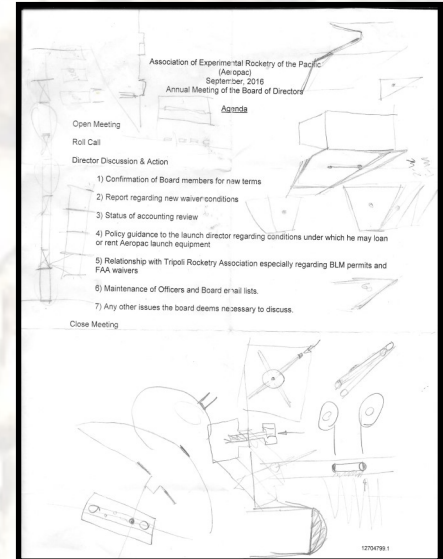

Photo by J. Slouber

As mass is one of the foremost factors in high performance rocketry I used thin walled filament wound fiberglass airframe. I also avoided using heavy components such as metal quick links and heavy 9 volt batteries.

## Juniper Slouber





One thing that worked against the mass aspect was the boat tail aft closure. It did however increase aerodynamics significantly. This addition translated to an average of 12 newtons less drag at 150m/s. Sadly the amount of processing power and access I have to good simulation software is limited. Autodesk Flow Design only allows speeds up to 150m/s while the top speed reached by the rocket was 588m/s. Through a series of simulations at different speeds I would be able to extrapolate that data up to those speeds but the simulation runs incredibly slowly— approximately 1 simulated second every 10 minutes. After running a design with and without the boat tail closure through Open Rocket I determined that its use adds about 1100 feet to the apogee.



Boat tail closure

The unusual compression on the nosecone is likely due to the fact that the nosecone in the model is a tangent ogive as opposed to a Von Karman nosecone which I'm actually using. The only nosecone that would perform better would be a 3/4 parabolic but as far as I'm aware those aren't widely manufactured. To better the aerodynamics I decided to use a A.P.E. (Atterberry Precision Engineering) tower launcher so I don't have to worry about launch lugs creating extra drag.

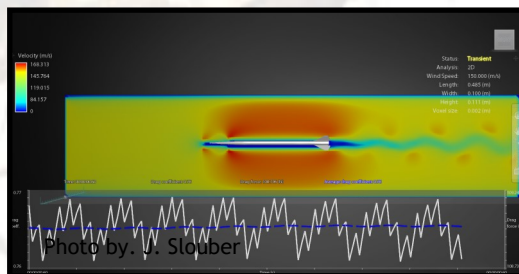

Simulation without boat tail

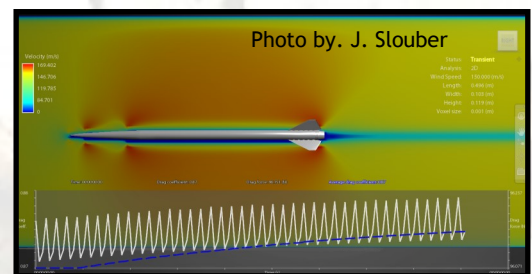

Simulation with boat tail

The fins are A.P.E. 54mm Airfoil series. I modified them to

have a mortise and tenon joint with the airframe like what Curt does. They were machined using a Laguna Swift CNC machine at my high school. Unfortunately the smallest spindle available was 1/8 inch. This caused the tips of the holes to be circular as opposed to square. This may result in some decreased strength. Due to some technical issues with the CNC machines I was unable to complete the fins yet, however that should be done within a couple of weeks.

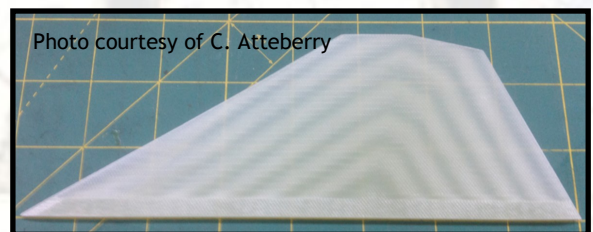

APE 54mm Double Taper Airfoil Machined G10 Fin set



The E-Bay is entirely housed within the nosecone. I had initially intended to house the parachute there as well but 54mm seems to be too small to do both of those in the same space. The electronics are mounted on a custom designed, 3D printed sled with specific mounting holes for the screw switches and the boards. The e-bay is equipped with two computers for redundancy: an Altus Metrum TeleMetrum and a Stratologger CF. The antenna on the TeleMetrum was much too long to fit without any bends. To fix this issue I mounted the board upside down and used an SMA extension cable for the antenna that curves 180°. This cuts off about 6cm from the original length of the board. Since I still don't have a HAM license I'm flying under Jonathan's call sign.

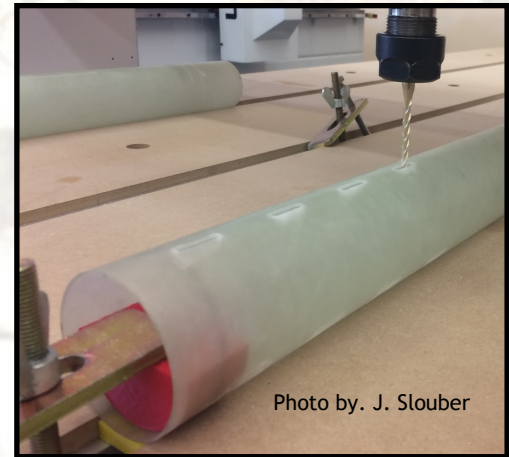
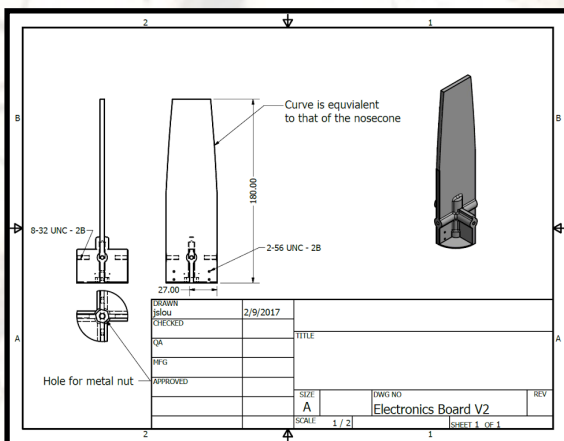

Photo by. J. Slouber

Cutting the mortises with the Laguna Swift CNC machine



Drawing by. J. Slouber

Left: Technical drawing of e-bay sled from Autodesk Inventor

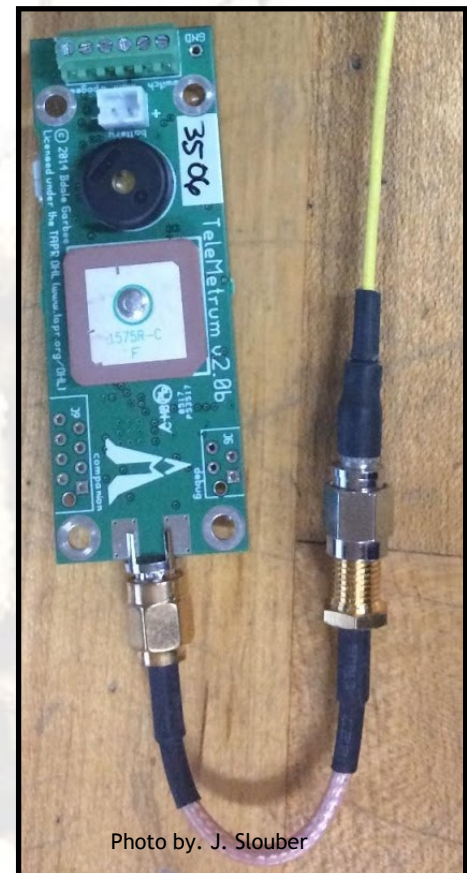

Photo by. J. Slouber

Nosecone Attachment Screw Hole; One of four

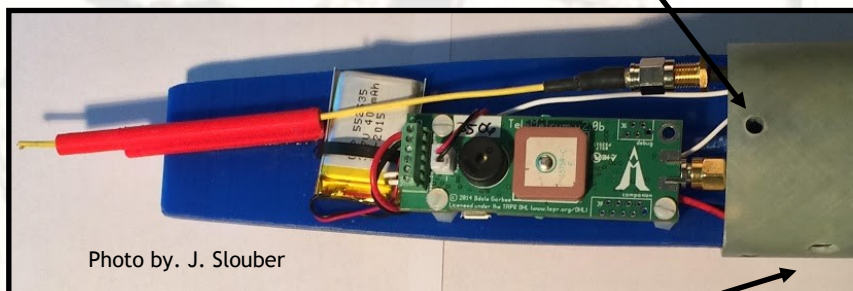

Photo by. J. Slouber

Screw Switch Hole



The rocket is specifically designed to fly the Aerotech K250W. Its estimated apogee is 26,344 feet. Unfortunately that's about 5300 feet short of the motor class record of 31,643 feet which I was hoping to break, placed by, of course: Curt. I had originally planned to use scratch built fins that would offer a apogee of 1300ft higher, due to the

fact that the A.P.E fins are about 20mm oversized for my rocket, but I couldn't figure out a good way to create the same airfoil that the A.P.E fins have. I am definitely still a novice with CNC and machining in general so I didn't want to take on such a advanced task so early on anyway.

I had hoped to have had the rocket completely done by now but the school took eight months to set up the CNC machines and without them the fin slots couldn't be done. I had originally planned to launch at MUDROCK 2017 but due to the flooding there's no way that's going to happen. Instead look for the launch at XPRS 2017; if the playa is even dry by then. Otherwise I might head up to Oregon to launch because that's the only other place that's fairly close and that has a high enough waiver.

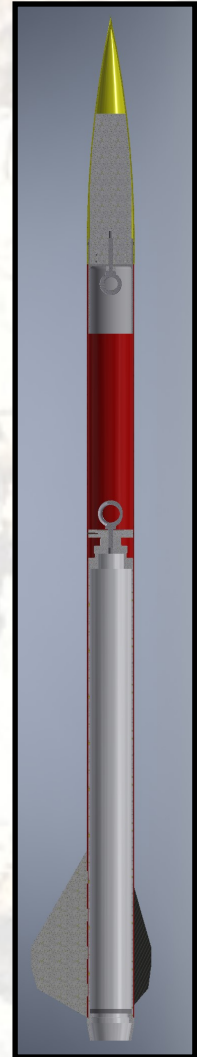

Right: Autodesk Inventor 3D model cross section

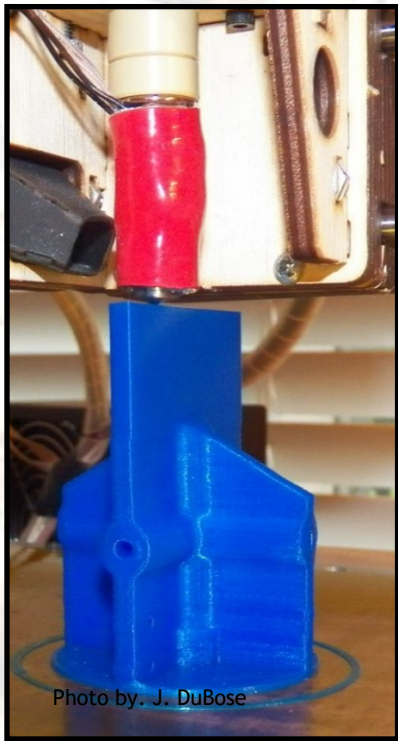
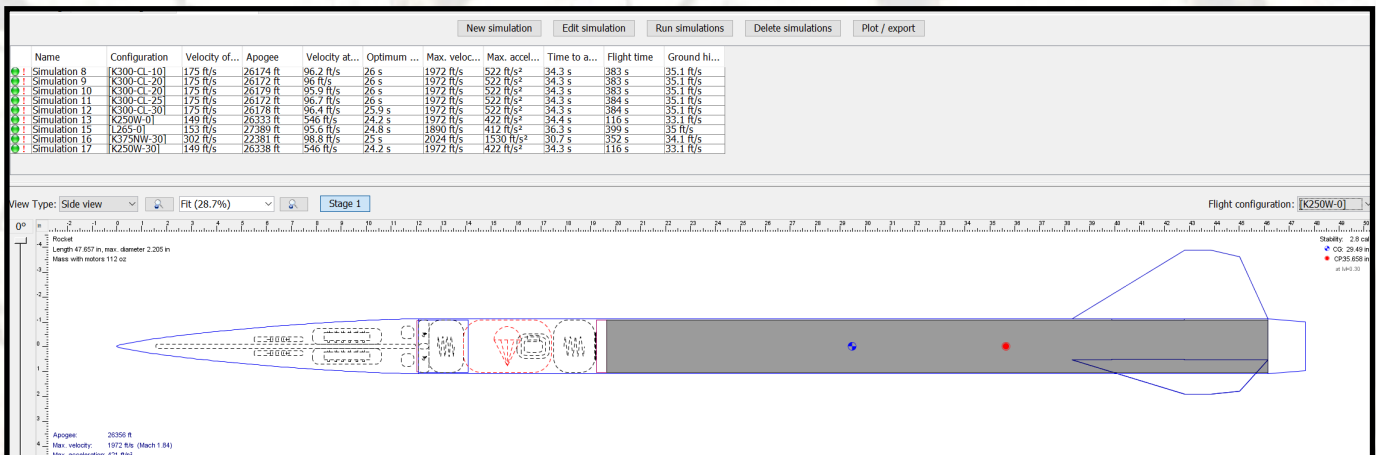

Photo by J. DuBose

Left: 3D printing the electronics sled



Bottom: Open Rocket simulates the flight to ~26,000





## Dr. Lynn Cominsky Wins More Awards

Prof. Lynn Cominsky has received the Frank J. Malina Educational award from the International Aeronautics Foundation. This award has been presented annually since 1986 to educators who have demonstrated excellence in taking the fullest advantage of the resources available to them to promote the study of astronautics and related space sciences. Cominsky will travel to Australia in September 2017 to receive the award at the 68<sup>th</sup> meeting of the International Aeronautical Congress. She will give a keynote lecture to the IAC and receive her medal at the end of the week-long meeting. The Malina award has a special significance to Prof. Cominsky, as prior to coming to SSU, she used to work with Frank Malina's son, Roger, who was the PI for the Extreme Ultraviolet Explorer satellite project at UC Berkeley. Frank Malina was an early aerospace pioneer who was also extremely interested in education and helped to found San Francisco's Exploratorium science museum.

As part of the LIGO authorship team, Cominsky also received a portion of the "Breakthrough Prize" bestowed by Russian entrepreneur Yuri Milner. Other prize-winners with SSU roots include Texas Tech Prof. Ben Owen (year) and Dr. Ryan Quitzow-James (year). The \$2 million award was shared by the 1000+ authors of the paper that announced the discovery of gravitational waves (ref here), with an additional \$1 million shared by the "troika" that founded LIGO: MIT Prof. Rai Weiss, Caltech Prof. Kip Thorne (who was Owen's Ph. D. thesis supervisor) and Scottish physicist Ron Drever.

\*\*\*\*\*

From the website: <http://www-glast.sonoma.edu/~lynnc/>

Background: Lynn Cominsky is the chair of the Physics and Astronomy department at Sonoma State University. She also directs SSU's Education and Public Outreach group, which develops innovative educational materials to inspire students in grades 5-14 to pursue STEM careers, to train teachers nationwide to use these materials in the classroom, and to enhance science literacy for the general public.

Question: Tell us about a hobby or passion outside of work.

Answer: I live on the Little H-bar Ranch with many animals, including 4 big horses, 2 miniature horses, 2 pygmy goats, 1 three legged goat, 1 dog, 3 cats, 5 chickens, a pheasant and a rescued baby black bird. When I am not riding horses, I like to go to the Black Rock Desert with the Aero-Pac rocket club to launch high-powered rockets.



Photo by Peter Hackett

Scene from Little H-Bar Ranch



## Largest rocketry inventory west of the Mississippi!



**BAR Gift Cards For the Grad Available! Call Mike at 510-461-0863 or send PayPal request to 510-461-0863 (add \$2.95 to amt).**

Watch for all the new AeroTech 98mm SuperThunder RMS motors, L2500/ 2gr, M4500/ 3gr , M6000/ 4gr & the O6000 DMS motor!

**SERVICE - EXPERIENCE - SAVINGS**

**BAY AREA ROCKETRY**

**Raising the BAR**

*"We treat our customers as we would like to be treated."*